

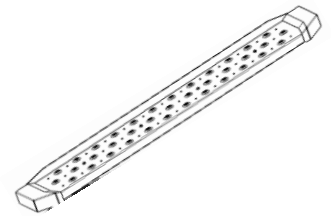

Running Board

Part No. RBV09B



Fits: 2015-Current Ford Transit Van (Full Size)



REMOVE CONTENTS FROM BOX. VERIFY ALL PARTS ARE PRESENT.



READ INSTRUCTIONS CAREFULLY BEFORE STARTING INSTALLATION.



DO NOT OVER TORQUE. STANDARD OPERATING LOAD FOR TIGHTEN BODY MOUNT NUTS & BOLTS VARIES FROM 7 TO 8.5 FOOT POUND FOR M6, 18 TO 20 FOOT POUND FOR M8 AND 35 TO 40 FOOT POUND FOR M10



60-180 min

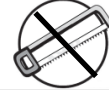

Cutting is not Required



Drilling is Required



support@trailfx.com



1 866 638 4870



POLISHED STAINLESS STEEL – LIMITED LIFETIME
POWDER COATED BLACK – 3 YEARS

PARTS LIST:

Qty	Part Description	Qty	Part Description
1	Driver/Left Rattler Running Board 32inch	1	8mm Threaded Insert Tool
1	Passenger/Right Rattler Running Board 96inch	1	8mm Threaded Insert
6	Mounting Brackets	26	8mm x 24mm OD x 2mm Flat Washers
1	Driver/Left Rear Mounting Bracket	15	8mm Lock Washers
2	10mm x 35mm Bolt Plates	1	8mm Hex Nut
4	10mm x 30mm OD x 2.5mm Flat Washers	10	8mm Nylon Lock Nuts
2	10mm Nylon Lock Nuts	14	8mm Clip Nuts
2	10mm Plastic Retainers	7	6mm Double Bolt Plates
4	8mm U-Bolts	14	6mm x 22mm OD x 2mm Flat Washers
1	8mm x 35mm Hex Bolts	14	6mm Lock Washers
15	8mm x 25mm Hex Bolts	14	6mm Hex Nuts

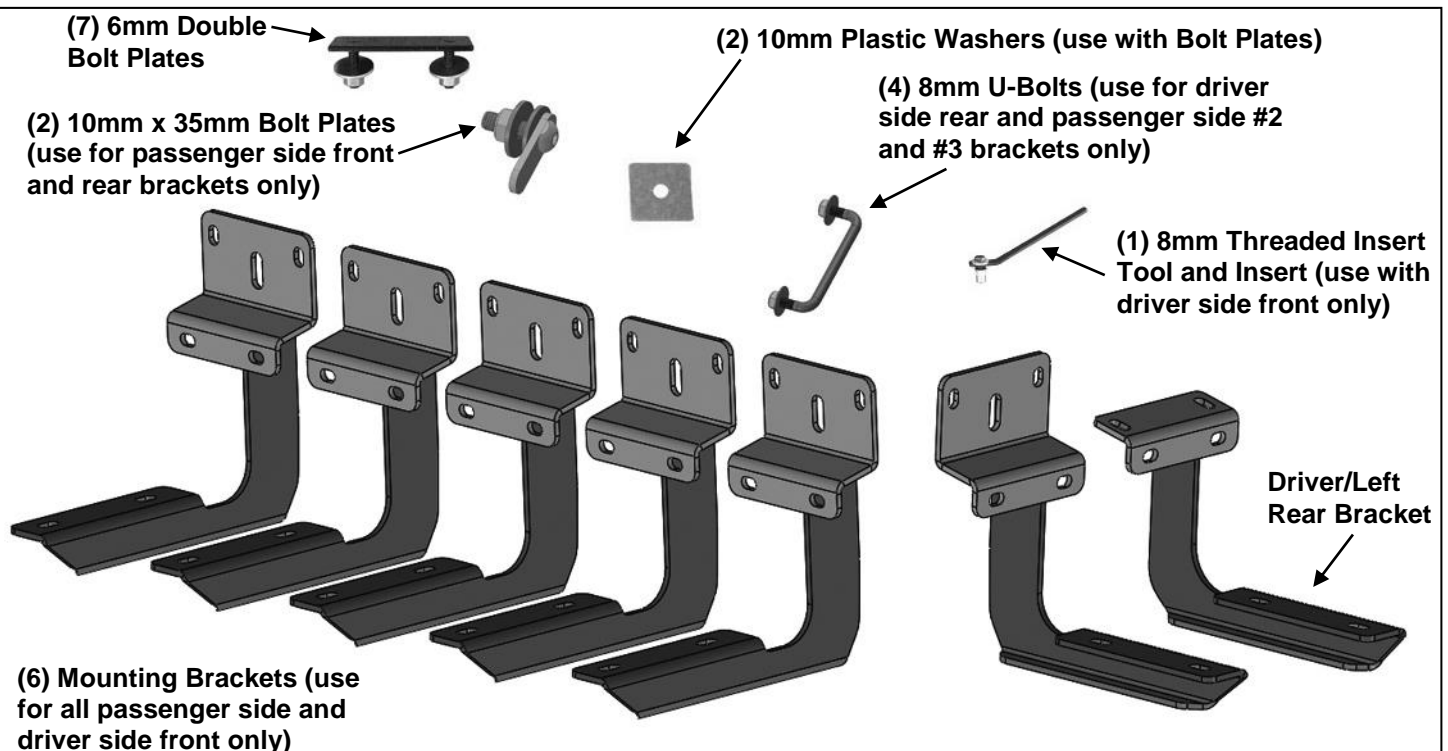

PROCEDURE:

REMOVE CONTENTS FROM BOX. VERIFY ALL PARTS ARE PRESENT. READ INSTRUCTIONS CAREFULLY BEFORE STARTING INSTALLATION. DRILLING IS REQUIRED. ASSISTANCE IS RECOMMENDED.

1. Start the installation under the passenger side of the vehicle. Release the lower clips from the plastic trim along the bottom of the body, **(Figure 1)**. **NOTE:** From below, insert a small or medium sized flat blade screwdriver into the rectangular hole in the center of the clip. Carefully release each side (inside to outside, not front to back) of the plastic clip and pull the rectangular center pin down from the clip, **(Figure 2)**. Do not twist the clip, gently pull it straight down once it is released. It is not necessary to completely remove the trim, only release the clips attaching the bottom of the trim to the vehicle.
2. Remove excess undercoating from all mounting locations so that Brackets will install flat against body panel and pinch weld.
3. **For models with factory studs:**
 - a. Select (1) Mounting Bracket.
 - b. Hold the Bracket firmly in position against the bottom and side of the body panel and mark the top left hole location onto the inner body panel. Mark the (2) lower slots in the Mounting Bracket in the pinch trim.
 - c. Using a 3/8inch drill bit, drill out the (2) marked areas.
 - d. Attach the Bracket to the studs (2) 8mm Flat Washers and (2) 8mm Nylon Lock Nuts, **(Figures 3 & 15)**. Do not tighten hardware.
 - e. Attach the Bracket to the pinch weld with (2) 8mm x 25mm Hex Bolts, (2) 8mm Lock Washers and (2) 8mm Flat Washers.
4. **For models without factory studs:**
 - a. Select (1) Mounting Bracket
 - b. Measure approx. 8inches to the front of the vehicle of the hole in the rocker panel, **(Figure 4)**. Select (1) Mounting Bracket. Hold the Bracket firmly in position against the bottom and side of the body panel and mark the top left hole location onto the inner body panel. Mark the (2) upper slots and lower slots in the Mounting Bracket on the body panel and the pinch trim.
 - c. Using a 3/8inch drill bit, drill out the (4) marked areas. **NOTE:** Do not drill through the outer body panel for the upper locations or damage to the body will result.
 - d. Select (1) 8mm U-Bolt. Insert the U-Bolt into (1) of the drilled holes and out of the other hole.
 - e. Select (2) 8mm Clip Nuts. Side the Clip Nuts over the pinch trim with the nut toward the outside.
 - f. Attach the Mounting Bracket to the U-Bolt with (2) 8mm Flat Washers and (2) 8mm Nylon Lock Nuts. Do not tighten hardware.
 - g. Attach the Bracket to the pinch weld with (2) 8mm x 25mm Hex Bolts, (2) 8mm Lock Washers and (2) 8mm Flat Washers.
5. Locate the factory hole approximately 24inches back from the front of the body, **(Figure 4)**.
6. Select (1) 10mm Bolt Plate, (1) 10mm Flat Washer and (1) 10mm Plastic Retainer, **(Figure 5)**. Thread the Retainer part way onto the Bolt Plate. Insert the Bolt Plate into the hole and tighten the Retainer against the body panel. Slide the 10mm Flat Washer onto the end of the Bolt Plate, **(Figure 6)**. **IMPORTANT:** The Plastic Retainer is designed to prevent the Bolt Plate from falling into the body panel and to aid in Bracket installation.
7. Select (1) Mounting Bracket. Line up the long slot in the center of the Bracket with the Bolt Plate and Flat Washer. Attach the Bracket to the Bolt Plate with (1) 10mm Flat Washer, (1) 10mm Lock Washer and (1) 10mm Hex Nut, **(Figure 7)**. Push the Bracket up tight against the bottom of the body and temporarily tighten the Hex Nut.
8. Mark the location of the (2) bottom slots in the Bracket onto the pinch weld, **(Figure 7)**. Remove the Bracket. Use a 3/8inch drill bit to drill (2) holes through the pinch weld only. **NOTE:** Drill the holes as far away from the bottom edge of the pinch weld as possible. **IMPORTANT:** Do not drill through the welds in the pinch weld. Slide the Bracket forward or back to move the slots away from the factory spot welds. Do not drill into or through the outer plastic rocker panel cover.

IMPORTANT! Any cutting or drilling tool may break or shatter. Government regulations require safety glasses & equipment at all times when cutting or drilling.

9. Select (2) 8mm Clip Nuts. Side the Clip Nuts over the pinch weld with the nut toward the outside, **(Figure 8)**. Reattach the Bracket to the Bolt Plate, **(Step 7)**. Attach the Bracket to the pinch weld with (2) 8mm x 25mm Hex Bolts, (2) 8mm Lock Washers and (2) 8mm Flat Washers, **(Figure 9)**. Leave hardware loose at this time.
10. Move along the body to the 3rd mounting location. Determine if the vehicle is equipped with factory mounting studs along the body panel.

Models without factory studs:

- a. Locate the (2) factory holes in the side of the body panel, **(Figure 10)**. Insert (1) 8mm Long U-Bolt into and through the (2) holes, **(Figure 11)**. Thread 8mm Plastic Retainers onto the ends of the U-Bolt to hold it in place. Select (1) Passenger side Bracket.

- b. Attach the Bracket to the U-Bolt with (2) 8mm Flat Washers, (2) 8mm Lock Washers and (2) 8mm Hex Nuts, **(Figure 12)**.
- c. Repeat **Steps 7—9** to drill and attach the bottom of the Bracket to the back of the pinch weld, **(Figure 13)**.
- d. Repeat to install (1) Bracket in the 4th mounting location, **(Figure 14)**.

Models with factory studs:

- a. Attach (1) Mounting Bracket to the factory studs with (2) 8mm Flat Washers, (2) 8mm Lock Washers and (2) 8mm Hex Nuts.
 - b. Repeat **Steps 7—9** to drill and attach the bottom of the Bracket to the back of the pinch weld, **(Figures 15 & 16)**.
 - c. Repeat to install (1) Mounting Bracket in the 4th mounting location.
11. Continue along the side of the vehicle to the rear mounting location, **(Figure 17)**. Repeat **Steps 2—9** to install (1) Mounting Bracket in the rear mounting location, **(Figures 17 & 18)**.
 12. Select the long Passenger/Right Running Board. Place the Running Board on top of the (5) Mounting Brackets. Select (5) 6mm Double Bolt Plates. Locate the channels in the bottom of the Running Board. Insert the Bolt Plates into the channels in the bottom of the Running Board closest to the Brackets, **(Figure 19)**. Lift the Running Board up and guide the studs through the Brackets.
 13. Attach the Running Board to the Brackets with (10) 6mm Flat Washers, (10) 6mm Lock Washers and (10) 6mm Hex Nuts, **(Figure 20)**. **NOTE:** The Running Board is designed to fit close to the vehicle. It may be necessary to loosen the Bracket hardware and tilt the Brackets downward to insert the Running Board between the Brackets and the body. Do not tighten hardware at this time.
 14. Level and adjust the Running Board and fully tighten all hardware. Reinstall the plastic trim along the bottom of the body. **IMPORTANT:** Minor trimming may be required around 8mm Clip Nuts. Temporarily remove the Running Board. Use a sharp knife or hacksaw blade to trim plastic as required.
 15. Move to the driver side of the vehicle. Repeat **Step 1**, **(Figures 1 & 2)**, to release the clips attaching the plastic trim to the bottom of the driver side.
 16. Determine if the vehicle is equipped with factory mounting studs at the front of the body panel.

Models without factory studs:

- a. Identify the front Bracket mounting location approx. 10inches back from the front of the body, **(Figure 21)**.
- b. Select (1) passenger/driver side front Bracket. Hold the Bracket firmly in position against the bottom and side of the body panel and mark the top left hole location onto the inner body panel. Also mark the (2) lower mounting locations onto the back of the pinch weld, **(Figure 21)**. **IMPORTANT:** Do not drill through the welds in the pinch weld. Slide the Bracket forward or back to move the slots away from the factory spot welds. Do not drill into or through the outer plastic rocker panel cover.
- c. Move the Bracket out of the way and drill a 7/16" hole through the body panel for the top of the Bracket, **(Figures 21 & 24B)**. Select (1) 8mm Threaded Insert, (1) 8mm x 35mm Hex Bolt, (1) 8mm Hex Nut, (1) 8mm Flat Washer and (1) 8mm Insert Tool. Thread the Hex Nut onto the Hex Bolt. Assemble the Tool as pictured in **Figure 22**. Use a 13mm wrench to hold the Hex Bolt to prevent it from spinning. Turn the Hex Nut clockwise to pull/expand the insert in the hole, **(Figure 23)**. Tighten the Hex Nut until the Insert is fully installed, **(Figures 24A & 24B)**. Do not overtighten the Hex Nut.
- d. Next, repeat **Steps 5 & 6** to drill the pinch weld and attach the bottom of the Bracket to the pinch weld, **(Figures 24B & 25)**. Attach the top of the Bracket to the previously installed Threaded Insert with (1) 8mm x 25mm Hex Bolt, (1) 8mm Lock Washer and (1) 8mm Flat Washer, **(Figure 25)**. Leave hardware loose at this time.
- e. **Models with factory studs:**

Models with factory studs:

- a. Repeat **Step 3** to attach (1) Mounting Bracket to the front location, **(Figures 26 & 27)**.
 - b. Repeat **Steps 8 & 9** to drill and attach the bottom of the Bracket to the the pinch weld, **(Figure 27)**.
17. Continue along the side of the body to the driver side rear mounting location approximately 24inches back from the front corner of the body, **(Figures 21 & 26)**. Select the unique Driver/left Rear Mounting Bracket. Hold the Bracket firmly against the bottom and back of the body panel. Slide the Bracket forward or back as necessary to avoid drilling through any welds on the pinch weld. Mark all (4) locations to drill, **(Figure 28)**.
 18. Drill (2) 7/16" holes through the bottom of the body panel as marked, **(Figure 28)**. Next, repeat **Step 8** to drill through the pinch weld to attach the bottom of the Bracket. Insert (1) 8mm Long U-Bolt into and through the (2) drilled 7/16" holes, **(Figure 29)**. Select the Driver/Left Rear Mounitng Bracket. Attach the top slots on the Bracket to the U-Bolt with (2) 8mm Flat Washers, (2) 8mm Lock Washers and (2) 8mm Hex Nuts, **(Figure 30)**. Repeat **Step 6** to attach the bottom of the Bracket to the back of the pinch weld. Leave all hardware loose at this time.
 19. Select the Driver/Left Running Board. Place the Running Board on top of the (2) Brackets. Select (2) 6mm Double Bolt Plates. Repeat **Steps 12 & 13** to attach the Running Board to the (2) Brackets.
 20. Level and adjust the Running Board and fully tighten all hardware. Reinstall the plastic trim along the bottom of the body. **IMPORTANT:** Minor trimming may be required around 8mm Clip Nuts. Use a sharp knife or hacksaw blade to trim plastic as required.

21. Do periodic inspections to the installation to make sure that all hardware is secure and tight.
To protect your investment, Do not use any type of polish or wax that may contain abrasives that could damage the finish. Mild soap may be used also to clean the Running Board.

Passenger/right Side Installation Pictured

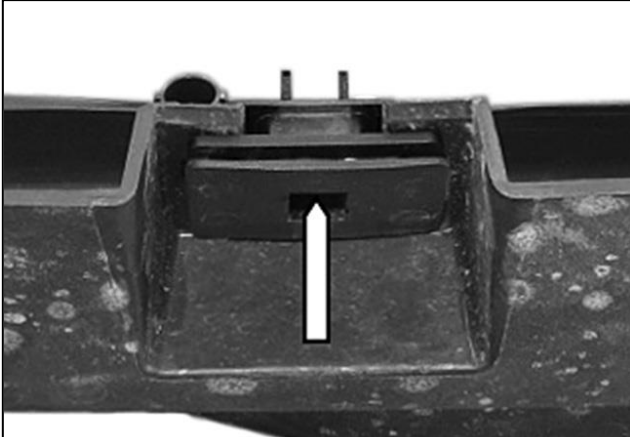

(Fig 1) Insert flat blade screwdriver into square opening in center of plastic clip to release

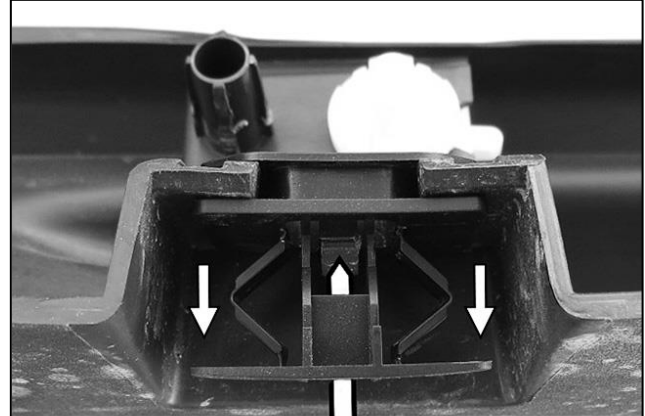

(Fig 2) Release both sides of clip and pull insert to release. Do not try to pull the clip out of the trim, only release clip as pictured

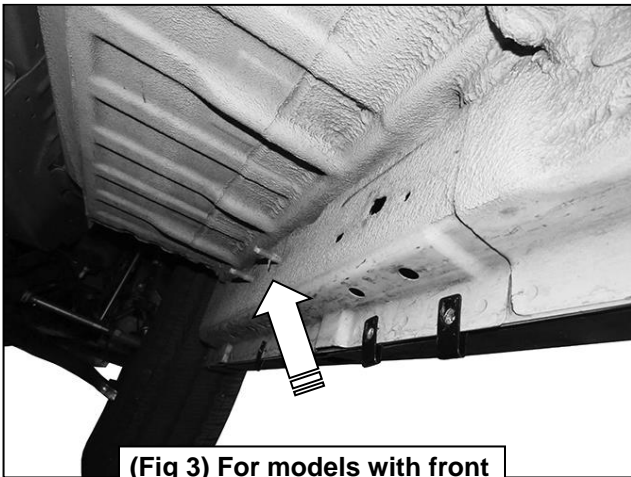

(Fig 3) For models with front factory studs shown



(Fig 5) Bolt Plate with Plastic Retainer

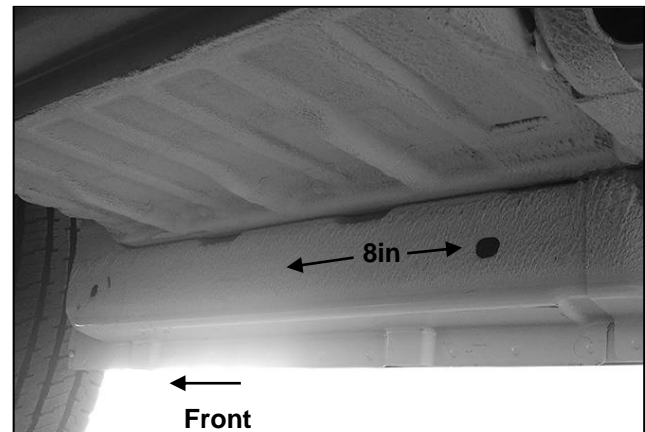

(Fig 4) For models without factory studs drilling is required. Hold up (1) Mounting Bracket 8inches in front of the hole and mark the upper slots for drilling. Insert (1) U-Bolt into the drilled holes. (See Figures 11 & 12)

Passenger/right Side Installation Pictured

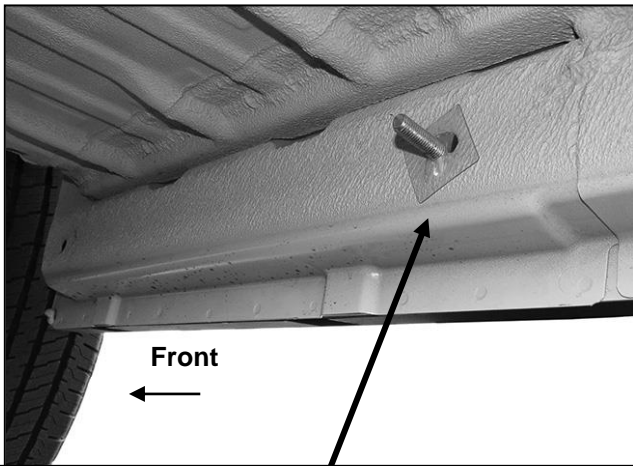

(Fig 6) Tighten Plastic Retainer to hold Bolt Plate

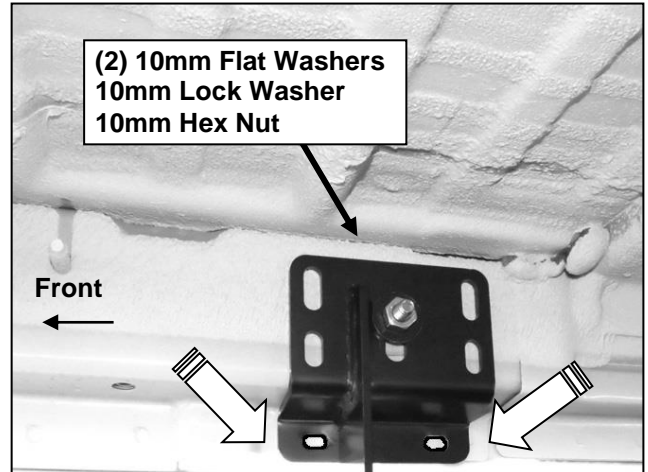

(Fig 7) Push Bracket up tight against body panel. Mark location of bottom slots onto pinch weld

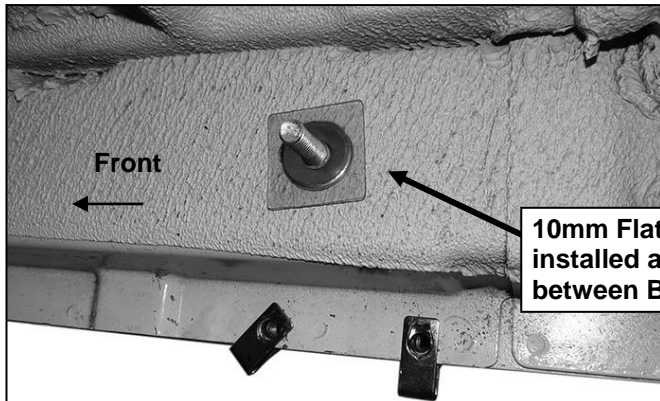

(Fig 8) Drill 3/8" holes through pinch weld. Slide 8mm Clip Nuts onto pinch weld over holes

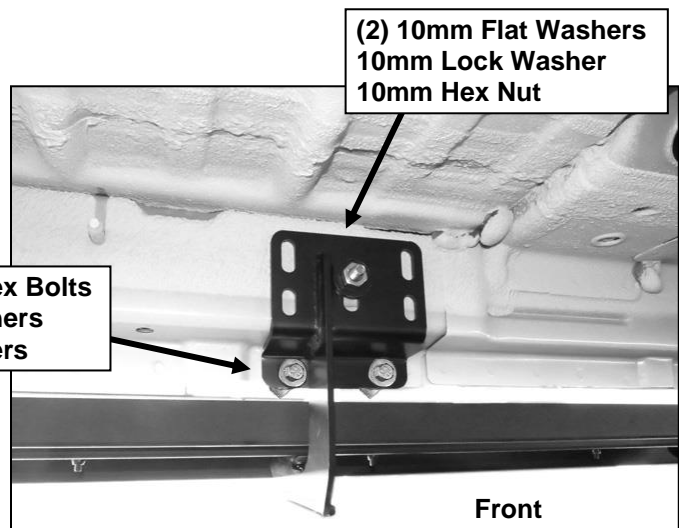

(Fig 9) Passenger side front Bracket installed

Passenger/right Side Installation Pictured

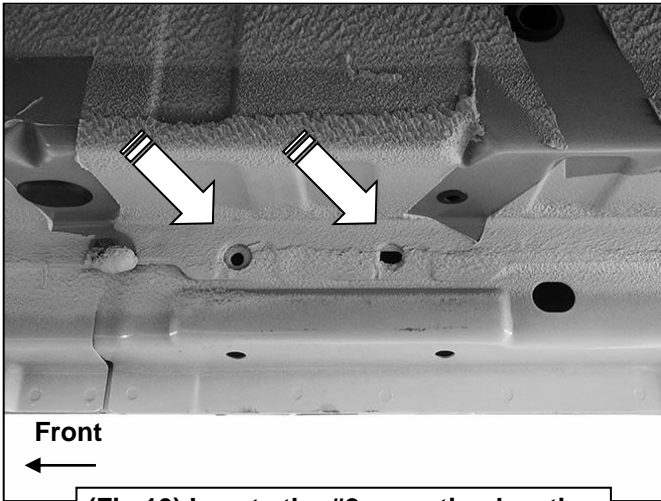

(Fig 10) Locate the #2 mounting location for Bracket. Insert 8mm U-Bolt into and out factory holes in body panel

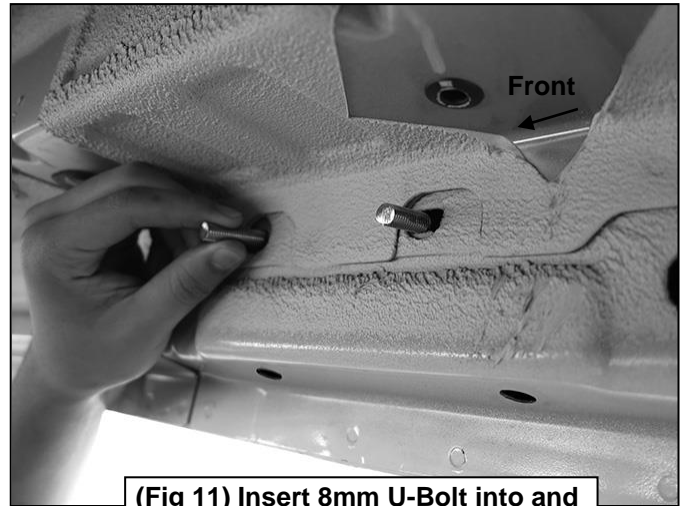

(Fig 11) Insert 8mm U-Bolt into and out factory holes in body panel

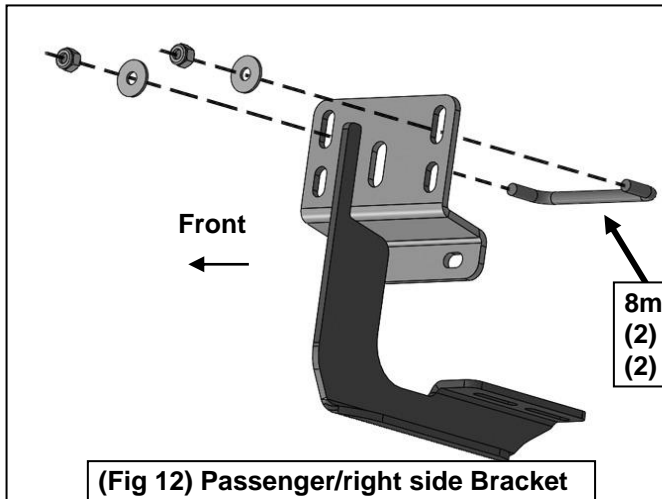

- 8mm U-Bolt
- (2) 8mm Flat Washers
- (2) 8mm Nylon Lock Nuts

(Fig 12) Passenger/right side Bracket attached to body panel with U-Bolt

Mark and drill 3/8" holes through pinch weld

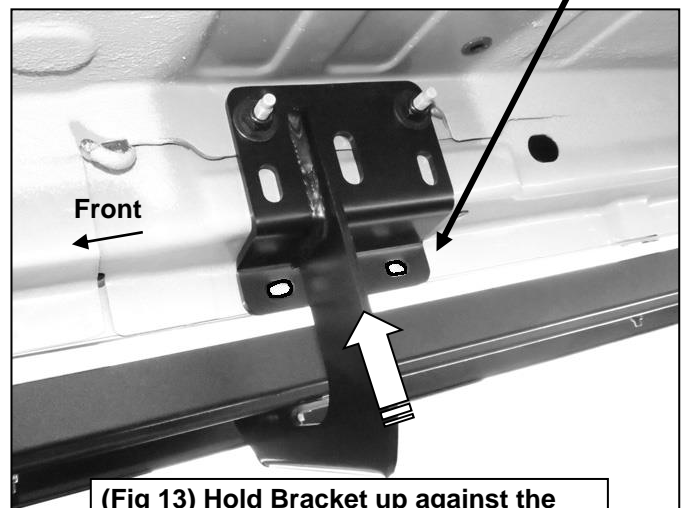

(Fig 13) Hold Bracket up against the pinch weld and mark slots for drilling

Passenger/right Side Installation Pictured

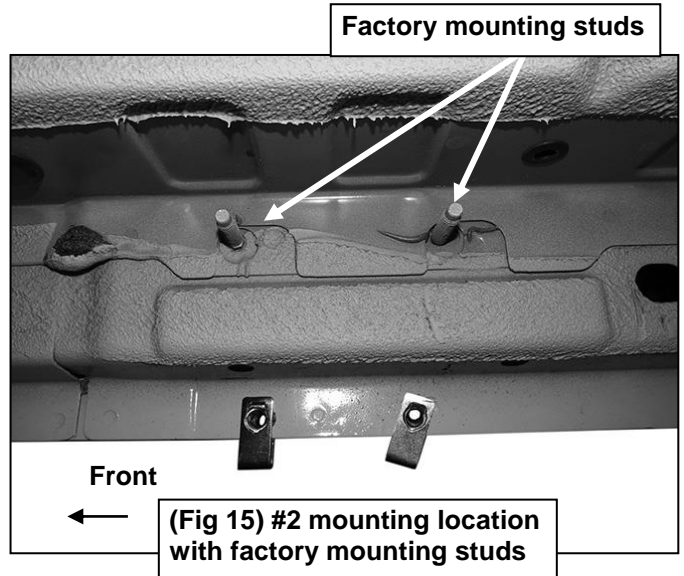
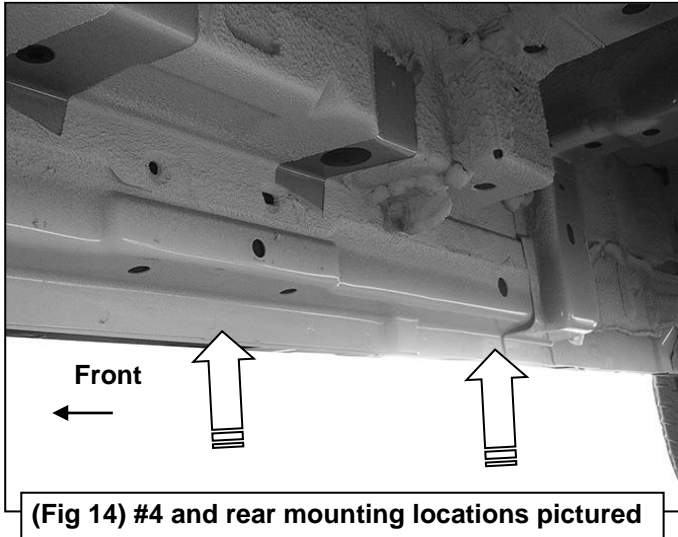

(2) 8mm Flat Washers
(2) 8mm Nylon Lock Nuts

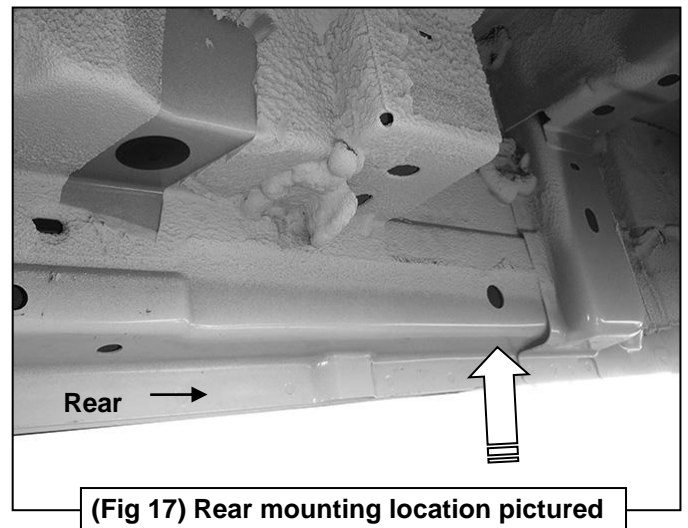
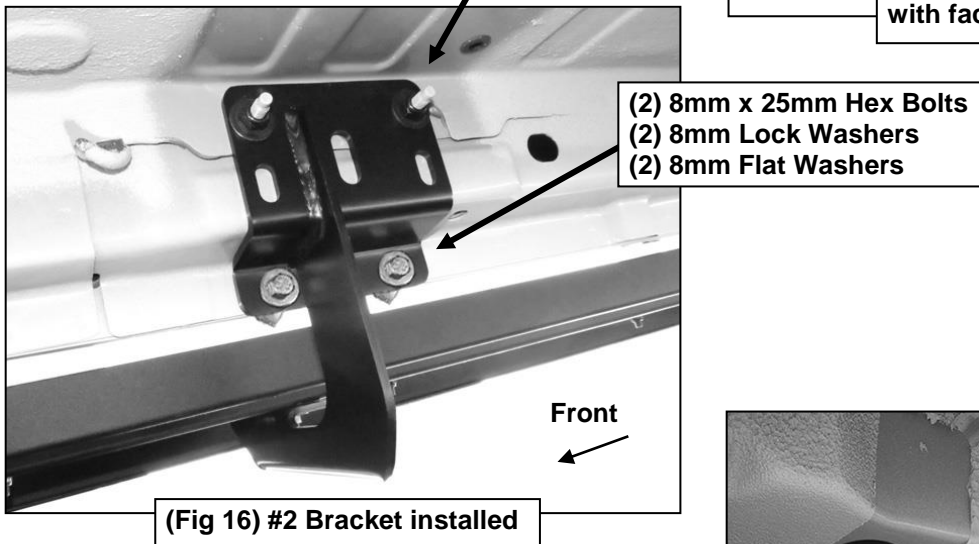

Passenger/right Side Installation Pictured

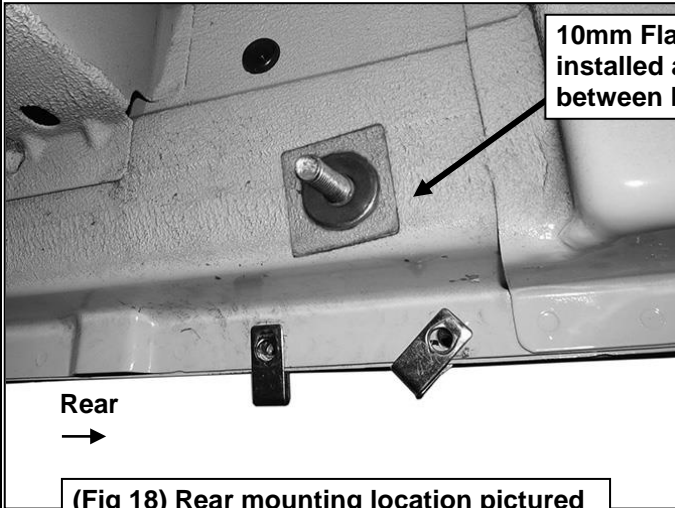

(Fig 18) Rear mounting location pictured

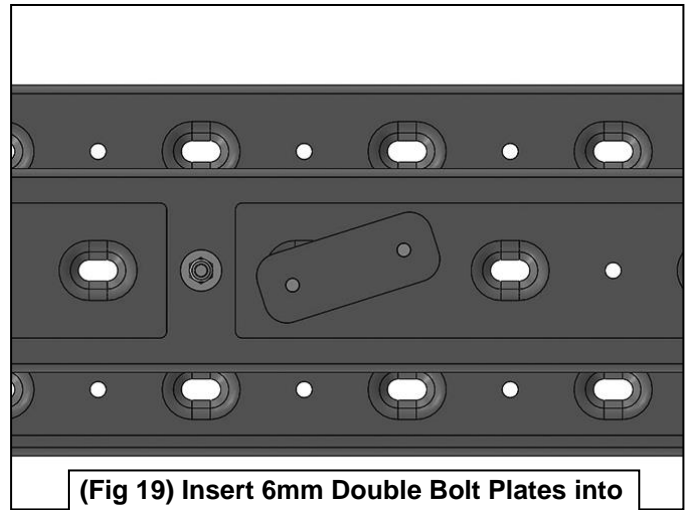

(Fig 19) Insert 6mm Double Bolt Plates into tracks on the bottom of the Running Board

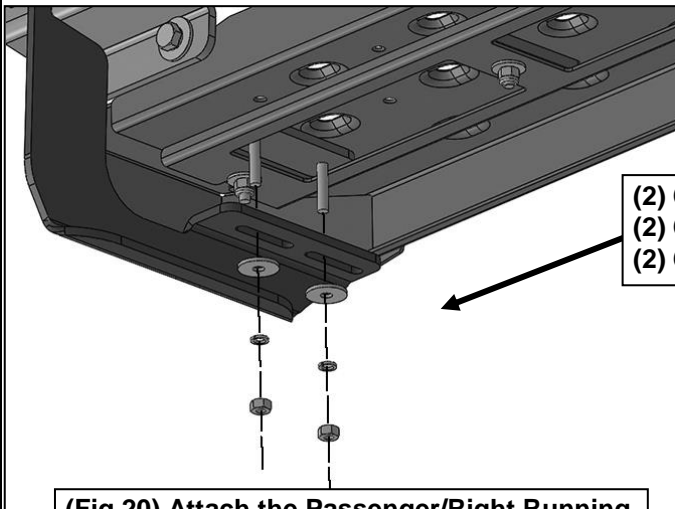

(Fig 20) Attach the Passenger/Right Running Board to the Mounting Brackets

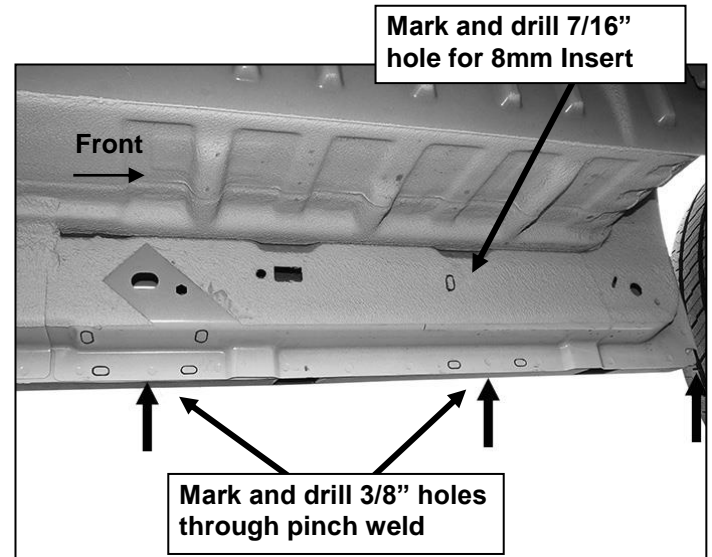

(Fig 21) Driver side front and rear mounting locations

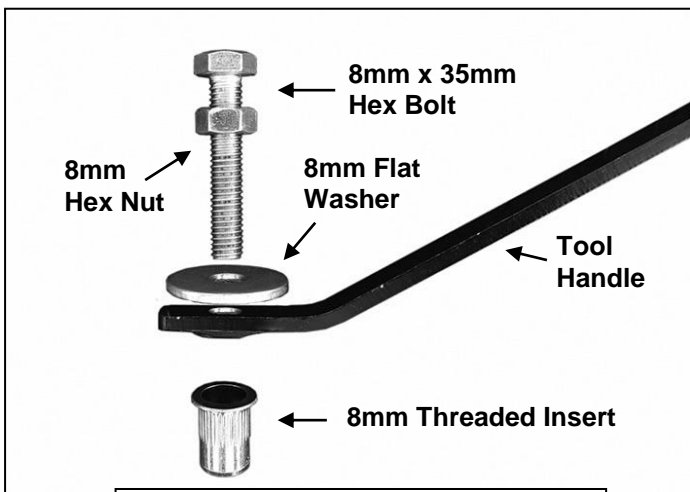

(Fig 22) Assemble 8mm Insert Tool

Driver/left Side Installation Pictured

Hold 8mm Hex Bolt in position with wrench.
Turn 8mm Hex Nut clockwise to "pull" insert



(Fig 23) Assemble 8mm Insert Tool

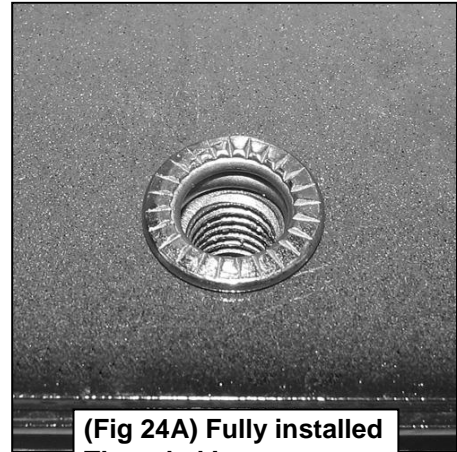

(Fig 24A) Fully installed Threaded Insert

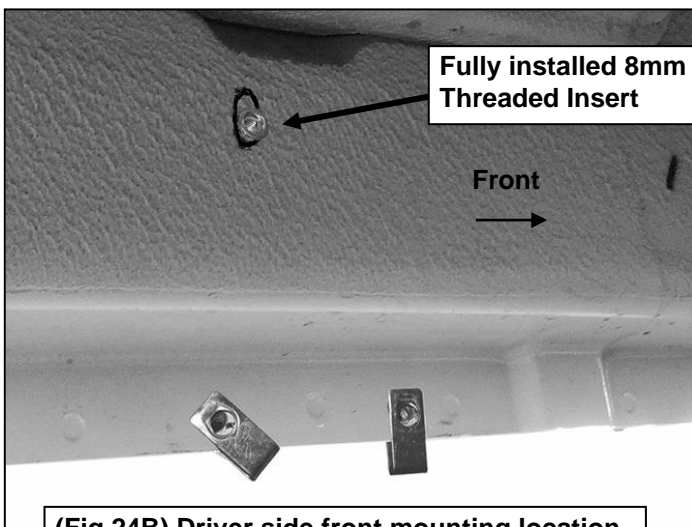

(Fig 24B) Driver side front mounting location

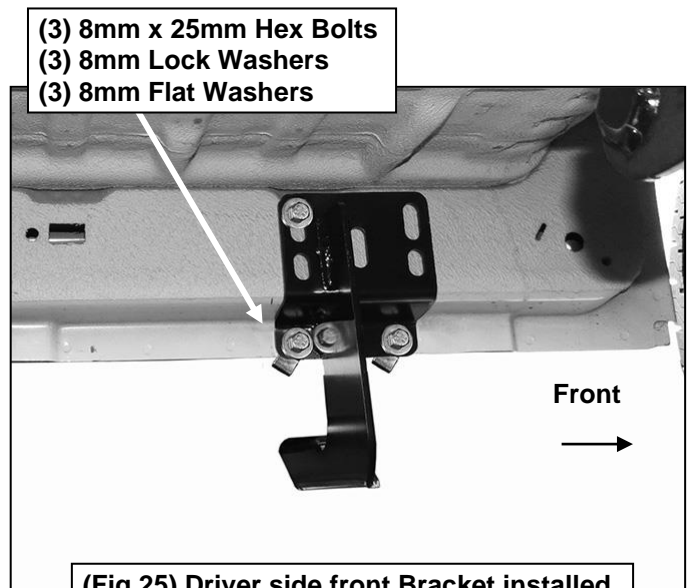

(Fig 25) Driver side front Bracket installed

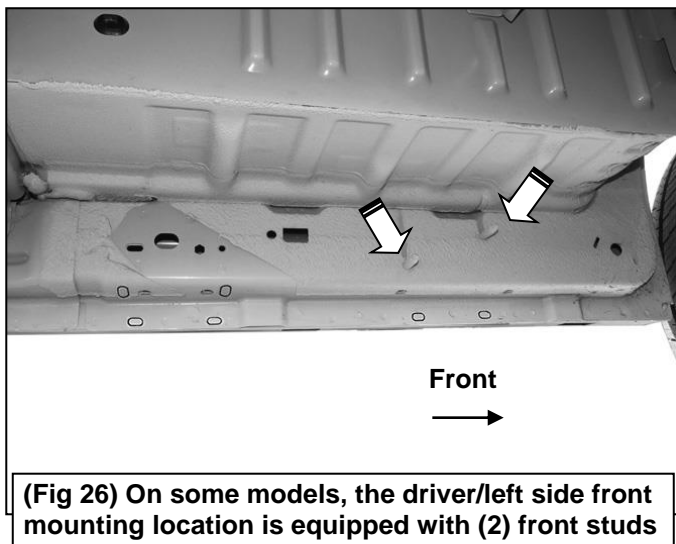

(Fig 26) On some models, the driver/left side front mounting location is equipped with (2) front studs

Driver/left Side Installation Pictured

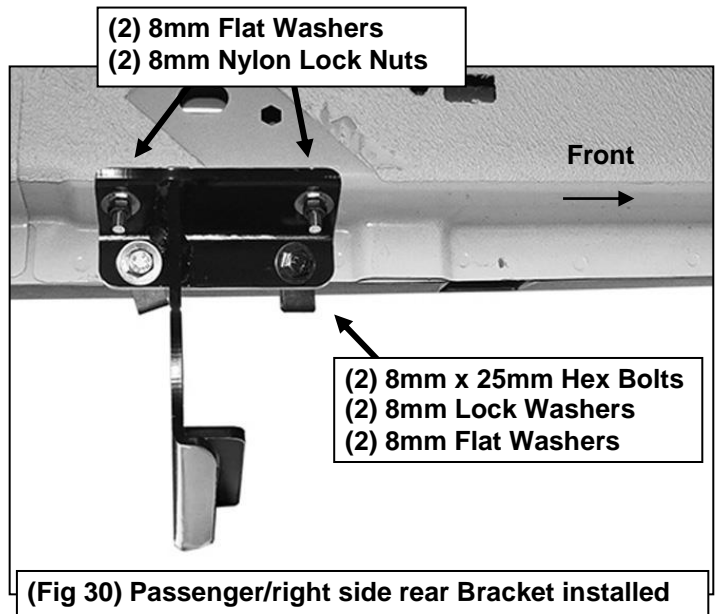
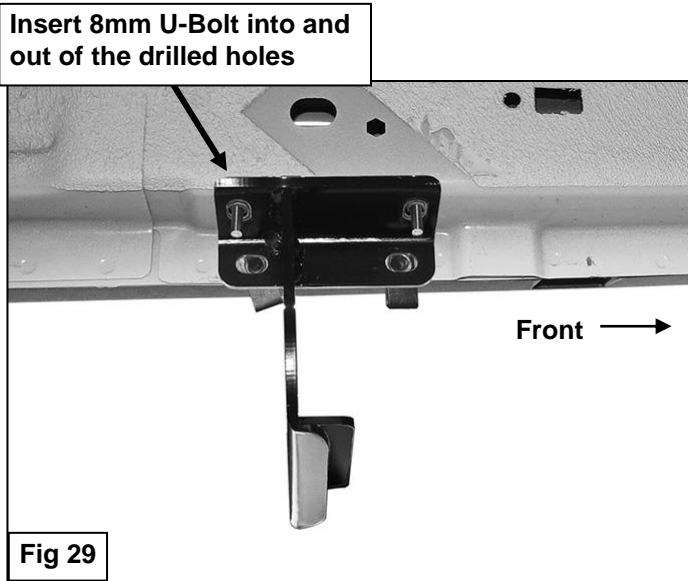
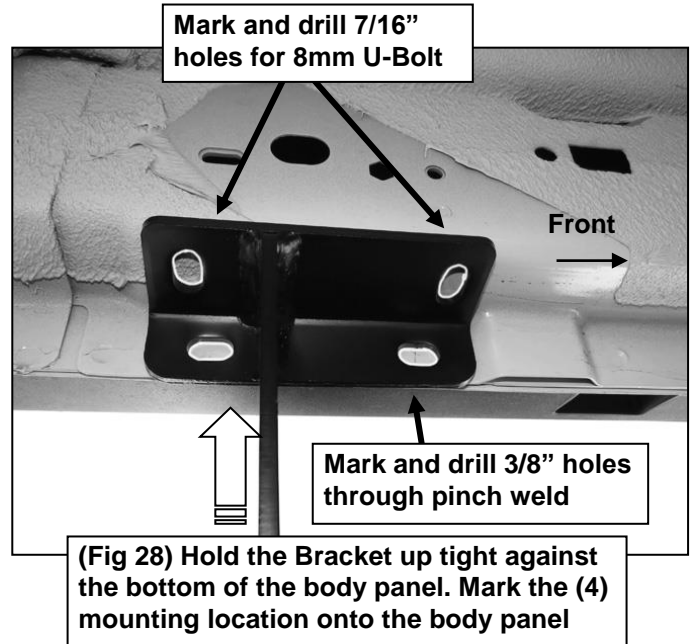
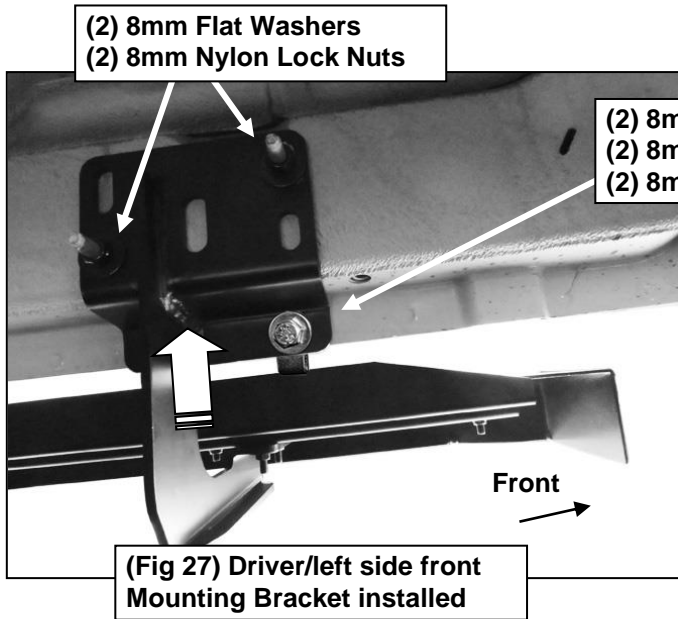

No.	Parts Identification
1	Passenger / Right 'Rear' Bracket marked "PR"
2	Driver / Left 'Rear' Bracket marked "DR"
3	Passenger / Right 'Center' Bracket marked "PC"
4	Driver / Left 'Center' Bracket marked "DC"
5	Passenger / Right 'Front' Bracket marked "PF"
6	Driver / Left 'Front' Bracket marked "DF"

Note:

- > This guide is to identify the parts and not a reference for part count.
- > For part count, refer Parts List.
- > Product / Bracket image is representative and actual design may vary.

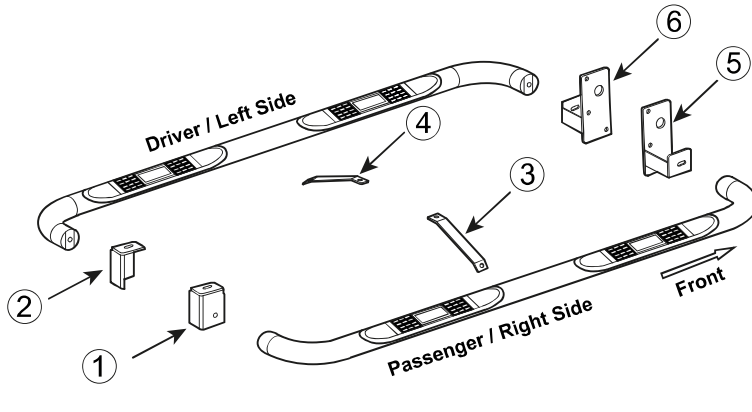

PRODUCT CARE

- Periodically check the product to ensure all fasteners are tight and components are intact.
- Regular waxing is recommended to protect the finish of the product.
- **Use ONLY Non-Abrasive automotive wax.** Use of any soap, polish or wax that contains an abrasive is detrimental and can scratch the finish leading to corrosion.
- Aluminum polish may be used to polish small scratches and scuffs for **Stainless Steel finish.**
- Mild soap may be used to clean the product for both **Stainless Steel and Black finish.**

FAQ's

1. Hardware's are not of correct size.

In GMC / Chevrolet truck model 2006 & up, customer needs to reuse the factory body bolts to install the bracket. If your vehicle is not GMC / Chevrolet 2006 & up, ensure that holes are not partially covered with any plastic grommet or rust? If it is, remove the plastic grommet & rust from the thread holes & re-try the installation.

2. Mounting Bracket are not getting Installed properly.

In some cases Illustration images shown in Installation manual may not be the exactly same as per actual vehicle images ,also if Driver / Passenger side mounting brackets are very identical in the design, suggest referring Parts Identification guide to avoid fitment issue.

3. Products are thumping / rattling after installation.

Ensure that all required mounting brackets / hardware's are installed & tighten correctly. Suggest using white lithium / regular grease between the metal to metal contact surfaces.

4. Side Bar is not aligning with vehicle / Step Pads are not aligning with vehicle doors.

Side bar may be interchanged or mounting brackets are not installed at the correct position in the vehicle. Refer Parts identification guide.

5. Missing / Excess Hardware.

Recheck hardware count as per the part list.

6. Product not installing properly.

Ensure make model year, cab length and bed size of your vehicle is listed in the application. All installation steps are followed correctly.

Check out these other TrailFX Products!!

www.TrailFX.com



Keystone Automotive Operations Inc. (KAO) warrants this product to be free of defects in material and workmanship at the time of purchase by the original retail consumer. KAO disclaims any other warranties, express or implied, including the warranty of fitness for a particular purpose or an intended use. If the product is found to be defective, KAO may replace or repair the product at our option, when the product is returned prepaid, with proof of purchase. Alteration to, improper installation, or misuse of this product voids the warranty. KAO's liability is limited to repair or replacement of products found to be defective, and specifically excludes liability for any incidental or consequential loss or damage.